

Thermocouple Series_(VER.08)

ODERRING INFOMATION

제품 규격 코드 부여 규정(T/C & R.T.D) 1/2

1. 센서의 종류(IN PUT)

TYPE	CODE	TYPE	CODE	TYPE	CODE	ADD CODE	REMARKS
B'	B	R'	R	S'	S		B = +630 ~ 1820℃ R = -50 ~ +1768℃ S = -50 ~ +1768℃ N = -270 ~ +1300℃ K = -270 ~ +1372℃ E = -270 ~ +1000℃ J = -210 ~ +1200℃ T = -270 ~ +400℃ PT100 = -200 ~ +650℃
T'	T	J'	J	E'	E		
K'	K	C'	C	N'	N		
G'	G	D'	D	PTC	L		
PT100Ω	P	PT500Ω	I	PT1000Ω(3-WIRE)	H		
NTC 5KΩ	O	NTC 10KΩ	M	PT1000Ω(2-WIRE)	U		
NTC 20KΩ	Q	NTC 49.12KΩ	A	NTC 0.942KΩ	F		
				SPECIAL	X		

2. 접점의 수량(ELEMENT PAIR)

TYPE	CODE	TYPE	CODE	TYPE	CODE	ADD CODE	REMARKS
SINGLE	S	DOUBLE	D	TRIPLE	T		SINGLE = 측온점 1개 DOUBLE = 측온점 2개 TRIPLE = 측온점 3개
NONE	N			SPECIAL	X		

3. 외경(OUT DIA)

외경이 제일 큰 순서부터 차례로 기록하며 구분을 위해 " () " 사용한다(단, 절연관은 생략)

예) 21.7(16,0.5) = TUBE(21.7) / 세라믹튜브(16) / ELEMENT(0.5)

4. 길이(LENGTH)

센서의 앞 단부터 차례로 기록하며 mm기준이며 1M이상인 경우는 m로 표시한다

예) 150+300+2M) = L 형으로 높이가 150이며 길이가 300이고 케이블이 2M임

5. 재질(MAT'L)

외경이 제일 큰 순서부터 차례로 표기한다

TYPE	CODE	TYPE	CODE	TYPE	CODE	ADD CODE	REMARKS
SUS304	4	SUS316&L	6	구리, 동	U		N : NORMAL / M : MAX SUS304 = N:800℃/M:1000℃ SUS316 = N:800℃/M:1000℃ SUS310 = N:1000℃/M:1100℃ SUS321 = N:900℃/M:1050℃ NCONEL = N:1000℃/M:1100℃ PTO = N:1400℃/M:1600℃ SIC = N:1500℃/M:1700℃
SUS310	0	SUS321	3	INCONEL	C		
SANDVIK	V	TITANIUM	W	SSA-A(PTO)	A		
HB	H	PT1	Z	SIC	I		
GLASS	G	TEFLON	T	SILICON	S		
철	F	RUBBER	R	PVC	P		
베크라이트	R	싸이런	L	주철	J		
NONE	N			SPECIAL	X		

6. 고정부 나사(THREAD) & 고정대(FLANGE)

고정부 나사&고정대의 형태코드 기입 후 크기, 종류, 재질, 이동여부 순으로 기입한다.

TYPE	CODE	TYPE	CODE	TYPE	CODE	ADD CODE	REMARKS	
나사	S	FPL	P	FLANGE	F		코드뒤에 순서대로 추가 @종류 PF>>F, PT>>T, NPT>>N, M나사>>M, UNF>>U @FPL패럴 재질 SUS>>S, TEF>>T, 동>>U, @FLANGE규격 JIS&KS>>J, ANSI>>A, DIN>>D @FLANGE 압력 5K>>5, 10K>>1, 20K>>2, #150>>0, #300>>3 @FLANGE형상 RF>>R, FF>>F 공통 @재질 SUS>>S, Fe>>F, @형태 이동형>>M, 고정형>>W	
패럴	L	SPECIAL	X	NONE	N			
나사의 피치는 표준규격에 준하고 특수한 경우는 "X"로 등록한다. 예1) FPL나사- PT1/4"*패럴TEF*나사SUS = P4TTS 예3) FLANGE - 15A*JIS&KS*10K*RF*SUS*이동식 = FLJ1RSM 예2) 나사-PT1/8"*SUS*용접 = S8TSW 예4) JIS10K20A*규격(J)*압력(F)*형상(F)*재질(S)*형태(M) = 코드 = MJ1FSM								
TYPE	CODE	TYPE	CODE	TYPE	CODE			
1/8"	8	1/4"	4	3/8"	3			인치 규격("), 미리규격(mm)은 나사규격 10A, 15, 20A 등은 후렌지 규격
1/2"	2	3/4"	5	1"	1			
1 1/4"	6	2"	7	3"	9			
4MM	A	6MM	B	8MM	C			
10MM	D	12MM	E	14MM	F			
16MM	G	18MM	H					
10A	K	15A	L	20A	M			
25A	O	32A	P	40A	Q			
50A	R	60A	S	80A	T			
100A	U	패럴1.5S	V	패럴2S	W			
패럴2.5S	Y							

7. 정도(CLASS or GRADE)

TYPE	CODE	TYPE	CODE	TYPE	CODE	ADD CODE	REMARKS
0.15%	1	0.25%	2	0.30%	3		*귀금속열전대 CLASS1 = ±1.5℃ 또는 ±0.0025tH *비금속열전대 CLASS1 = ±1.5℃ 또는 ±0.004tH CLASS2 = ±2.5℃ 또는 ±0.0075tH *측온저항체(R.T.D) CLASS1 = ±(0.15+0.002tH) CLASS2 = ±(0.3+0.005tH)
0.40%	4	0.50%	5	0.75%	7		
0.10%	8	1.00%	0				
MAKER STD	M			SPECIAL	X		

ODERRING INFOMATION

제품 규격 코드 부여 규정(T/C & R.T.D) 2/2

2022.04.21

8. 머리부위 종류(HEAD TYPE)						ADD CODE	REMARKS
TYPE	CODE	TYPE	CODE	TYPE	CODE		
중형(SL)	G	소형(SS)	M	대형	L	코드뒤에 순서대로 추가 @ CABLE GRAND SIZE PF3/8>>0, PF1/2>>1, PF3/4>>2, PF1>>3 SPECIAL>>S -----선택사항----- @ SAT>>T	3/8" = 10A 1/2" = 15A 3/4" = 20A 1" = 25A
중형(SS)	A	중형(DY)	Y	중형(OMEGA)	O		
방폭형(DY)	D	단면두형	A	단면양두형	B		
방수,진,압형	C	노출형(중형)	J	벽걸이형	I		
노출형(소형)	S	소형(DY)	W	방폭형(SS-비인중)	H		
NONE	N			SPECIAL	X		

9. 연장선의 종류(LEAD WIRE)					
소선 피복부터 외측으로 순서대로 부여한다.					
소선의 타입은 1항, 소선 가닥수는 2항의 조건에 따른다.					

TYPE	CODE	TYPE	CODE	ADD CODE	REMARKS
GL/GL	GG	PVC/PVC	PP	코드뒤에 순서대로 추가 @종류 단선/일반>>1, 단선/스페셜>>2 연선/일반>>3, 연선/스페셜>>4 -----선택사항----- @굵기 0.32mm>>3, 0.4mm>>4, 0.5mm>>5, 0.6mm>>6, 0.65mm>>7 18AWG>>A, 20AWG>>B, 22AWG>>C 24AWG>>D, 26AWG>>E, 28AWG>>F 30AWG>>G, 32AWG>>H, 36AWG>>I 0.14SQ>>S, 0.3SQ>>J, 0.5SQ>>K, 1.25SQ>>L, 1.3SQ>>M, 2.0SQ>>O 2.3SQ>>R 0.2SQ>>Q -----선택사항----- @선택재질 구리+니켈도금>>P, SUS>>S, NONE>>N	PVC = -20 ~ +100°C TEF = -60 ~ +200°C SILICON = -20 ~ +200°C GLASS FIBER = 0 ~ +200°C (GL) CERAMIC FIBER = 0 ~ 1205°C (CFCF) SH : SHIELD(편조)
GL/SH	GS	PVC/SH	PS		
GL/SH/GL	GH	PVC/SH/PVS	PH		
GL/GL/SH	GI	PVC/PVC/SH	PI		
TEF/TEF	TT	SIL/SIL	SL		
TEF/SH	TS	SIL/SH	SS		
TEF/SH/TEF	TH	SIL/SH/SIL	SH		
TEF/TEF/SH	TI	SIL/SIL/SH	SI		
CERAMIC(CFCF)	CC	CERAMIC(HCFHCF)	CH		
휴대용 코드	HC	SUS TUBE(플렉시블)	ST		
수축튜브	RT	젤 수축튜브	CT		
TEF/GL/SH	TG	TEF/SIL	TL		
NONE	N	SPECIAL	X		

10. 단자대 , 처리(TERMINAL)						ADD CODE	REMARKS
TYPE	CODE	TYPE	CODE	TYPE	CODE		
"I"형 터미널	I	"Y"형 터미널	Y	"O"형 터미널	O	코드뒤에 순서대로 추가 @SIZE 3mm>>3, 4mm>>4, 5mm>>5, 6mm>>6, 8mm>>8, 10mm>>1, 15mm>>9, 20mm>>2, -----선택사항----- @내열온도 고온>>H	MALE / FEMALE은 코넥터 규격 SET는 MALE&FEMALE
MINI MALE	A	MINI FEMALE	B	MINI SET	Q		
STD MALE	C	STD FEMALE	D	STD SET	R		
내열용(STD MALE)	M	내열용(STD FEMALE)	U	내열용 SET(STD)	W		
세라믹(STD MALE)	E	세라믹(STD FEMALE)	F	세라믹 SET(STD)	S		
플라스틱	P	LEAD탈피	L	투명 Plate	K		
휴대용 손잡이(대형)	G	휴대용 손잡이(DJ)	J				
휴대용 손잡이(소형)	H						
NONE	N	절단	T	SPECIAL	X		

11. 감지부 형태(TIP SHAPE)						ADD CODE	REMARKS
TYPE	CODE	TYPE	CODE	TYPE	CODE		
GROUND	G	UNGROUND	U	EXPOSED	E		GROUND : 접지형 UNGROUND : 비접지형 EXPOSED : 노출형
PAD(표면용)	P						
NONE	N			SPECIAL	X		

12. QUALITY ASSURANCE						ADD CODE	REMARKS
TYPE	CODE	TYPE	CODE	TYPE	CODE		
자체(생산)	P	자체(품질)	Q	국가공인	G	코드뒤에 추가 @TAG.NO 유무 유>>O, 무>>X	
샘플링	S			기타(출장검사)	E		

- * 제품의 형태는 첨부된 기본도면을 기준으로 한다.
예) 1630 SHEATH THERMOCOUPLE 일반형
- * 특수한 경우는 유사 형태에 먼저 "S"를 붙인다.
예) S1630 SHEATH THERMOCOUPLE 특수형
- * 제품 규격 코드는 상위부터 순서대로 부여한다.
예) 도면 번호 2860 T/C 21.7 850L 310 이동형 FLANGE 25A JIS 10K RF SUS, 0.25 대형 HEAD(15A) U/G 자체(생산)
코드 : R*D*21.7(17,0.5)*500+350*0*OJ1RSM*2*L1*N*N*G*P
- * 사양이 필요없는 경우도 "N" 등록하고 다음 사양을 명기한다.
- * SPECIAL(X)는 코드에는 상세내용을 기입하지않고 도면을 참조하며 코드부여는 정해진 코드만 사용한다.
- * 추가로 필요한 사양은 별도 협의한다.
- * 내부 절연관은 현장 사용 온도 기준에 따른다.
(K TYPE : HB , R/S TYPE : PTO 기본적용)
- * PT100Ω은 3-WIRE 방식을 기준으로 하고 2-WIRE or 4-WIRE시 SPECIAL로 표기하고 도면에 기입한다.

Sheath Type

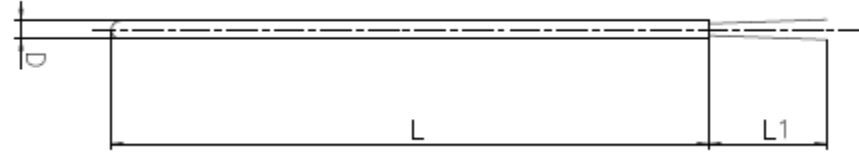
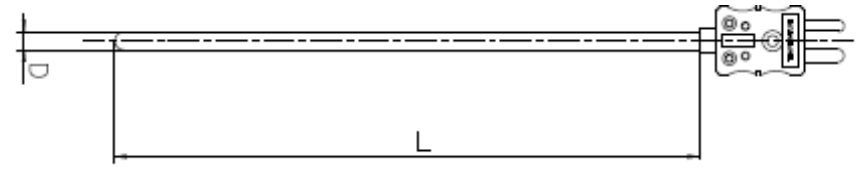
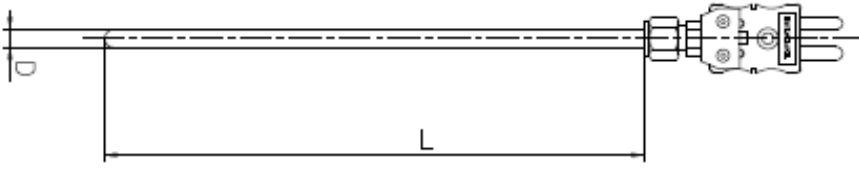
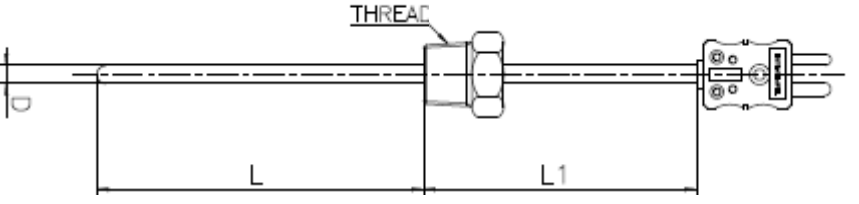
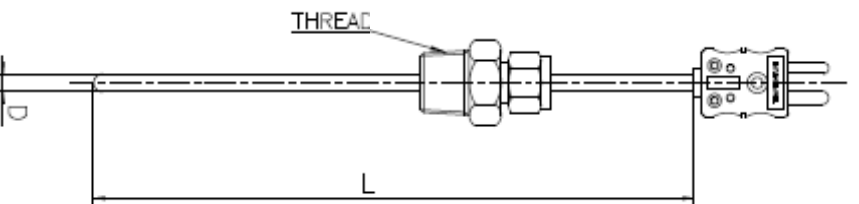
기본형식 Basic Model	외관형상 Appearance Shape
ISL-1000	
ISL-1010	
ISL-1020	
ISL-1030	
ISL-1040	

Sheath Type

기본형식 Basic Model	외관형상 Appearance Shape
ISL-1050	
ISL-1060	
ISL-1070	
ISL-1080	
ISL-1090	

Sheath Type

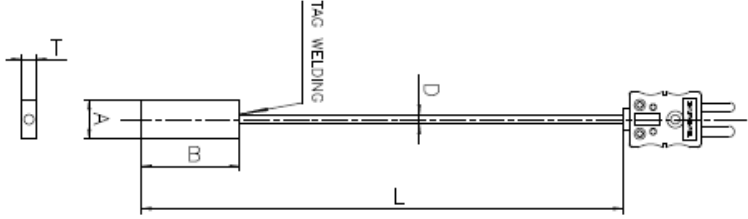
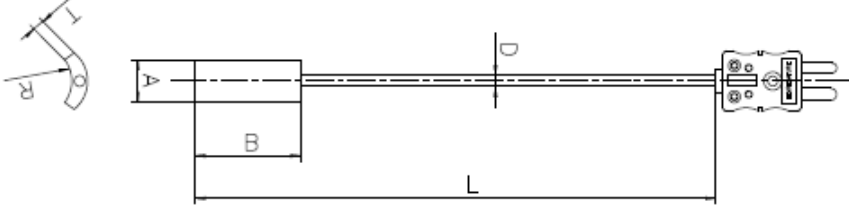
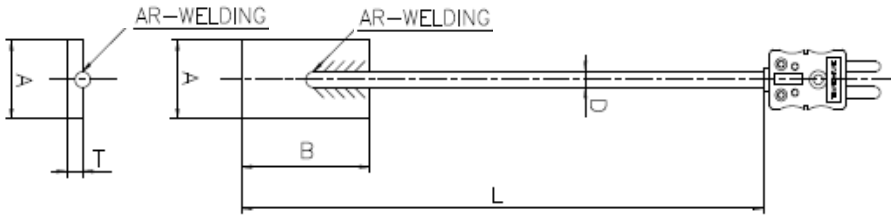
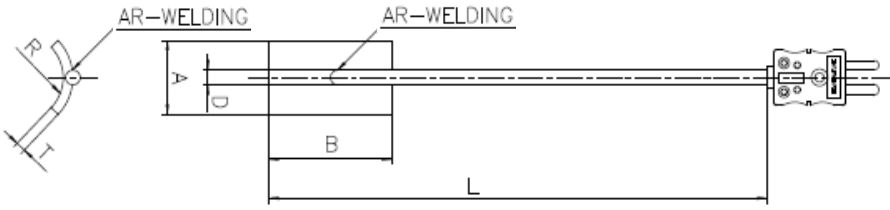
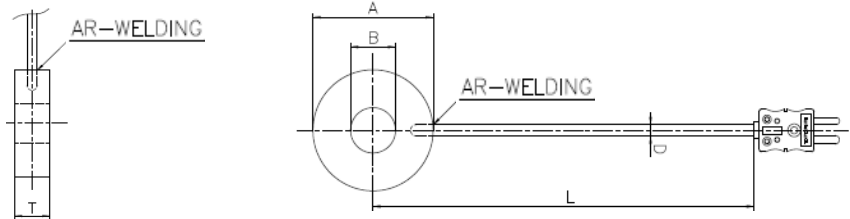
기본형식 Basic Model	외관형상 Appearance Shape
ISL-1100 HOW TO ORDER :	
ISL-1101	
ISL-1110	
ISL-1111	
ISL-1120	

Sheath & Lead Wire Type

기본형식 Basic Model	외관형상 Appearance Shape
ISL-1200	<p>Technical drawing of the ISL-1200 thermocouple. It shows a straight cylindrical sheath with diameter D. The total length is divided into three sections: a length L from the tip to the junction, a 40mm section for the junction housing, and a length L_1 for the lead wire. A break symbol is shown in the lead wire section.</p>
ISL-1201	<p>Technical drawing of the ISL-1201 thermocouple. It features an L-shaped sheath. The horizontal section has a length L_1 to the junction, a 40mm junction housing, and a length L_2 for the lead wire. The vertical section has a length L and diameter D. A break symbol is present in the lead wire section.</p>
ISL-1210	<p>Technical drawing of the ISL-1210 thermocouple. It shows a straight cylindrical sheath with diameter D. The junction housing is threaded and labeled "THREAD" and "WELDING". The length from the tip to the junction is L, the junction housing is 40mm long, and the lead wire length is L_1. A break symbol is shown in the lead wire section.</p>
ISL-1211	<p>Technical drawing of the ISL-1211 thermocouple. It features an L-shaped sheath with diameter D. The junction housing is threaded and labeled "THREAD" and "WELDING". The horizontal section has a length L_1 to the junction, a 40mm junction housing, and a length L_2 for the lead wire. The vertical section has a length L. A break symbol is present in the lead wire section.</p>
ISL-1215	<p>Technical drawing of the ISL-1215 thermocouple. It shows a straight cylindrical sheath with diameter D. The junction housing is threaded and labeled "THREAD". The length from the tip to the junction is L, the junction housing is 40mm long with an outer diameter D_1, and the lead wire length is L_1. A break symbol is shown in the lead wire section.</p>

Sheath & Lead Wire Type

기본형식 Basic Model	외관형상 Appearance Shape
ISL-1216	
ISL-1220	
ISL-1230	
ISL-1231	
ISL-1240	

Sheath & Lead Wire Type

기본형식 Basic Model	외관형상 Appearance Shape
ISL-1241	
ISL-1250	
ISL-1260	
ISL-1270	
ISL-1280	

Sheath & Lead Wire Type

기본형식 Basic Model	외관형상 Appearance Shape
ISL-1290	
HOW TO ORDER :	
ISL-1300	
HOW TO ORDER :	
ISL-1310	
HOW TO ORDER :	
ISL-1320	
HOW TO ORDER :	
ISL-1330	
HOW TO ORDER :	

Sheath & Lead Wire Type

기본형식 Basic Model	외관형상 Appearance Shape
ISL-1340	<p>Technical drawing of ISL-1340 thermocouple. It features a main sheath with diameter D and length L. A threaded section with diameter D2 and length L1 is attached to the end. A nut and washer are used to secure the lead wire, which has length L3. The connection is labeled 'WELDING'.</p>
ISL-1350	<p>Technical drawing of ISL-1350 thermocouple. It shows a main sheath with diameter D and length L. A threaded section with length L1 is attached to the end. The lead wire has length L2. The connection is labeled 'AR WELDING'.</p>
ISL-1360	<p>Technical drawing of ISL-1360 thermocouple. It shows a main sheath with diameter D and length L. A threaded section with length L1 is attached to the end. The lead wire has length L2. The connection is labeled 'AR WELDING'.</p>
ISL-1380	<p>Technical drawing of ISL-1380 thermocouple. It shows a main sheath with diameter D and length L. A threaded section with length L1 is attached to the end. The lead wire has length L1. The connection is labeled 'AR WELDING'.</p>
ISL-1390	<p>Technical drawing of ISL-1390 thermocouple. It features a main sheath with diameter D and length L. A threaded section with diameter D1 and length L1 is attached to the end. The lead wire has length L2. The connection is labeled 'THREAD'.</p>

Sheath & Lead Wire Type

기본형식 Basic Model	외관형상 Appearance Shape
ISL-1400	
<div style="background-color: #e0e0e0; width: 100%; height: 30px; border: 1px solid black; border-radius: 5px;"></div>	
<div style="background-color: #e0e0e0; width: 100%; height: 30px; border: 1px solid black; border-radius: 5px;"></div>	
<div style="background-color: #e0e0e0; width: 100%; height: 30px; border: 1px solid black; border-radius: 5px;"></div>	
<div style="background-color: #e0e0e0; width: 100%; height: 30px; border: 1px solid black; border-radius: 5px;"></div>	

Sheath Type & Terminal head Type

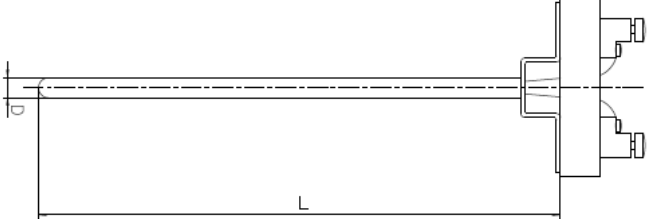
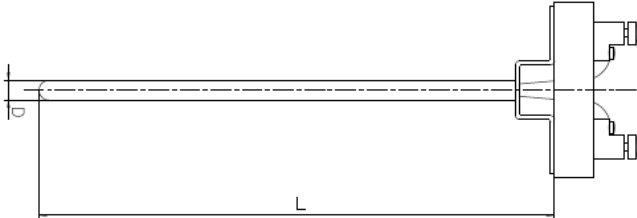
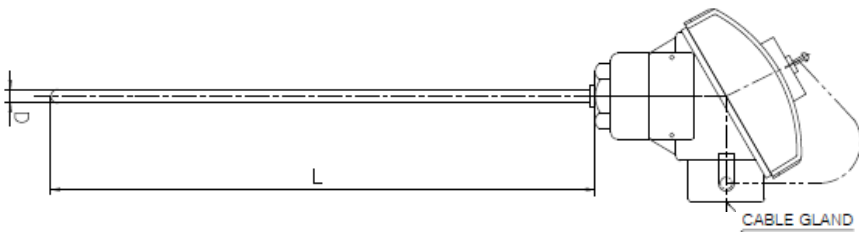
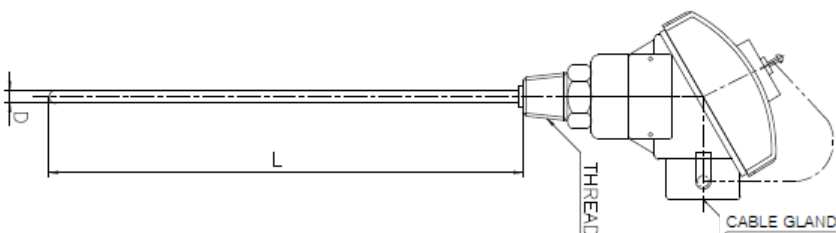
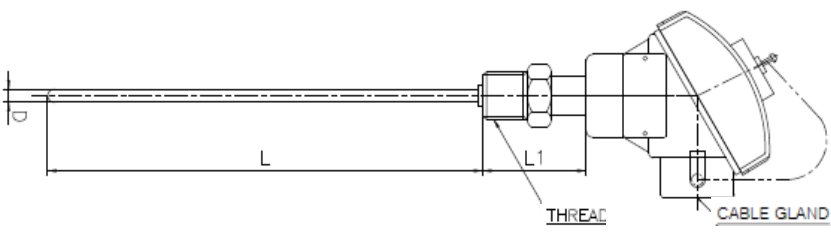
기본형식 Basic Model	외관형상 Appearance Shape
ISL-1500	
ISL-1510	
ISL-1520	
ISL-1530	
ISL-1540	

Sheath Type & Terminal head Type

기본형식 Basic Model	외관형상 Appearance Shape
ISL-1550	
ISL-1560	
ISL-1570	
ISL-1580	
ISL-1590	

Sheath Type & Terminal head Type

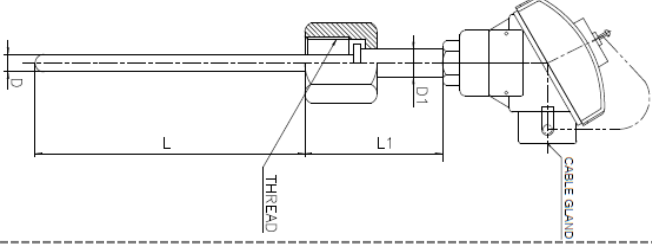
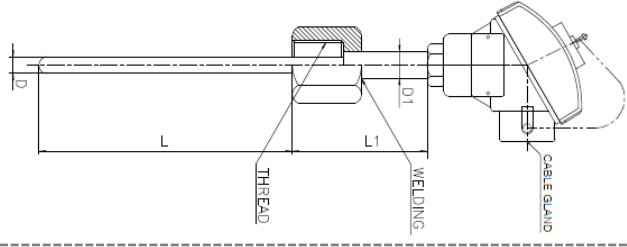
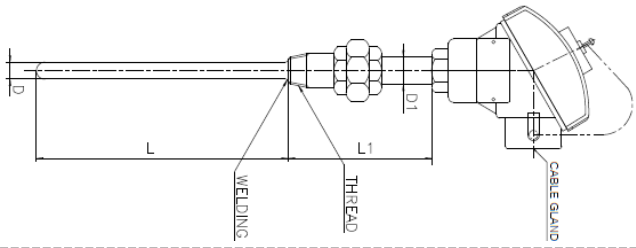
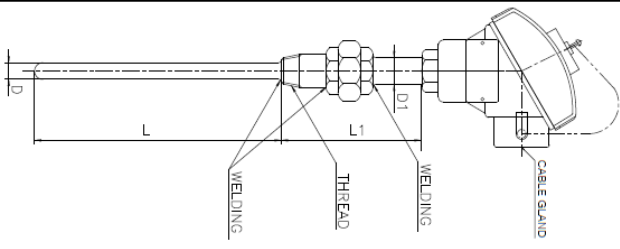
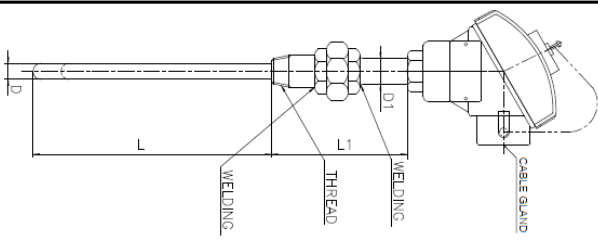
기본형식 Basic Model	외관형상 Appearance Shape
ISL-1600	
HOW TO ORDER :	
ISL-1610	
HOW TO ORDER :	
ISL-1620	
HOW TO ORDER :	
ISL-1630	
HOW TO ORDER :	
ISL-1640	
HOW TO ORDER :	

Sheath Type & Terminal head Type

기본형식 Basic Model	외관형상 Appearance Shape
ISL-1650	
ISL-1660	
ISL-1670	
ISL-1680	
ISL-1690	

Sheath Type & Terminal head Type

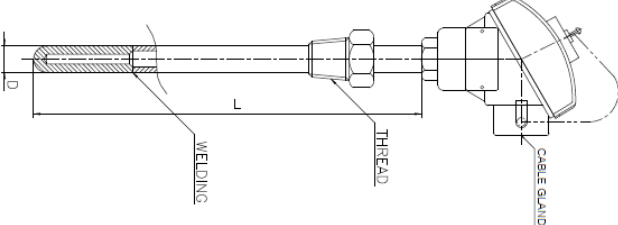
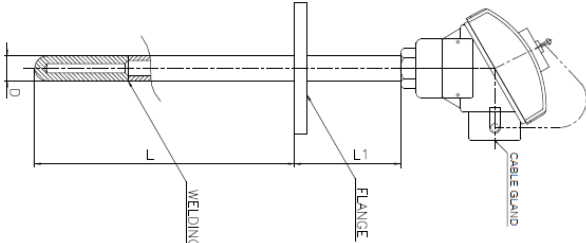
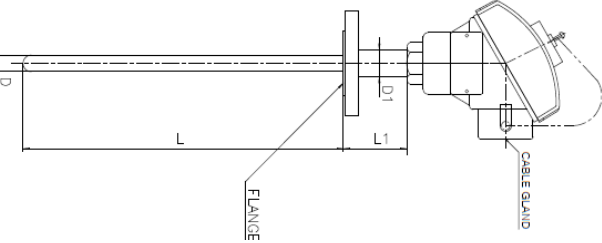
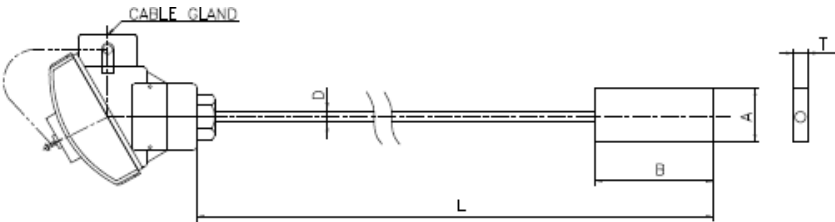
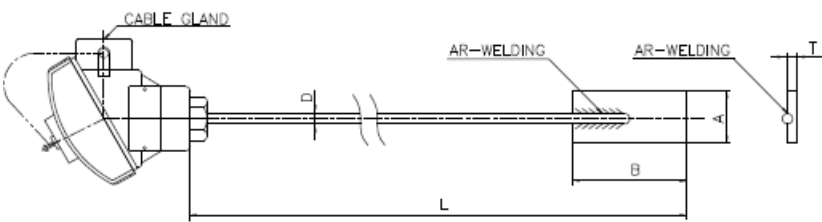
기본형식 Basic Model	외관형상 Appearance Shape
ISL-1700	
HOW TO ORDER :	
ISL-1710	
HOW TO ORDER :	
ISL-1720	
HOW TO ORDER :	
ISL-1730	
HOW TO ORDER :	
ISL-1740	
HOW TO ORDER :	



Sheath Type & Terminal head Type

기본형식 Basic Model	외관형상 Appearance Shape
ISL-1750	
ISL-1760	
ISL-1770	
ISL-1780	

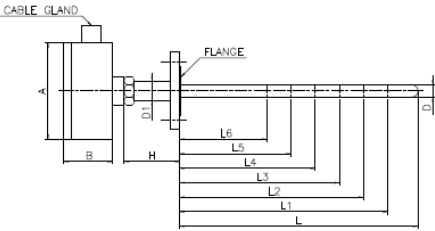
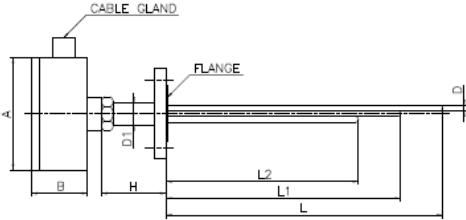
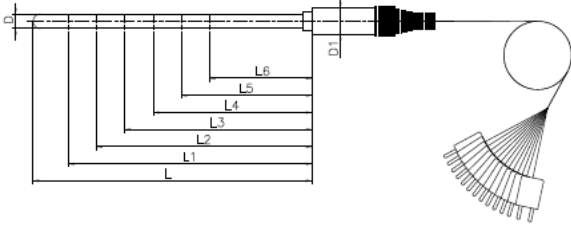
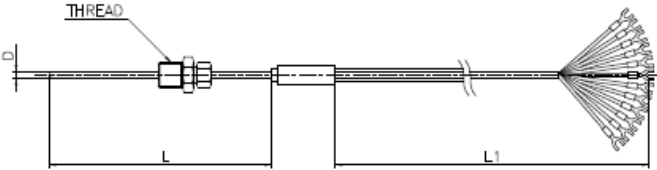
Multi Point Type

기본형식 Basic Model	외관형상 Appearance Shape
ISL-1900	
ISL-1910	
ISL-1920	
HOW TO ORDER :	
ISL-1930	
HOW TO ORDER :	
ISL-1940	

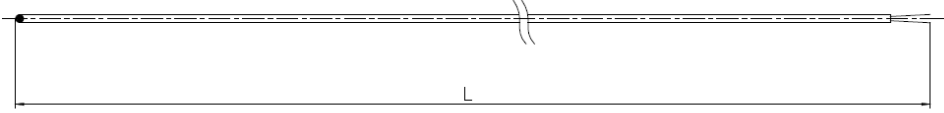
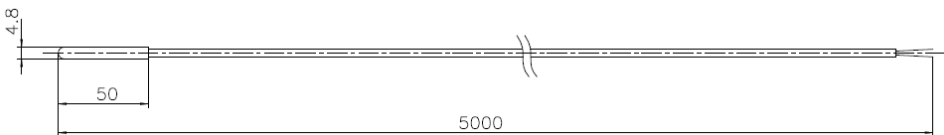
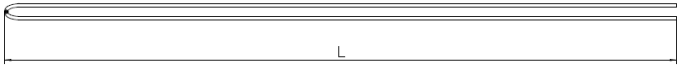
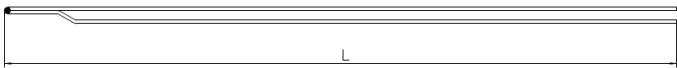

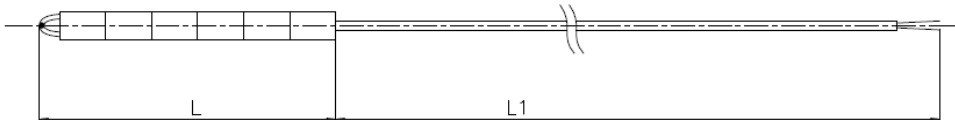
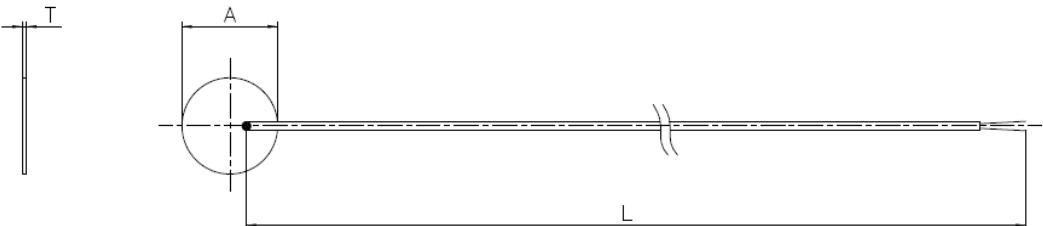
Tube & Wire Type

기본형식 Basic Model	외관형상 Appearance Shape
ISL-2000	
ISL-2010	
ISL-2020	<p>A-TYPE </p> <p>B-TYPE </p> <p>C-TYPE </p>
ISL-2030	
ISL-2040	

Tube & Wire Type

기본형식 Basic Model	외관형상 Appearance Shape
ISL-2050	
ISL-2060	
ISL-2070	
ISL-2080	
ISL-2090	

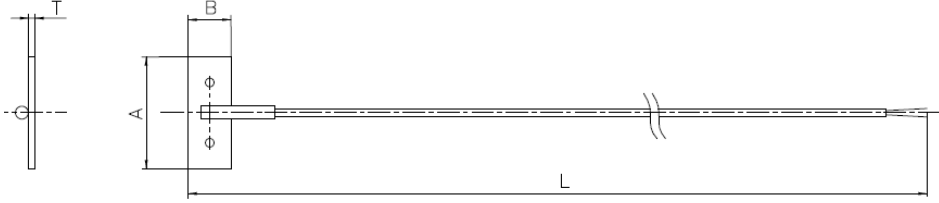
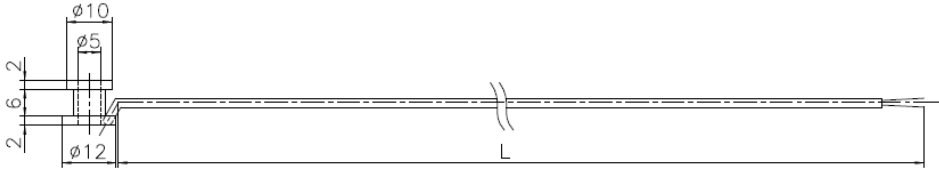
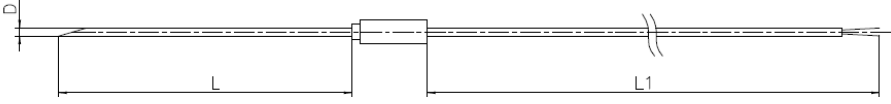
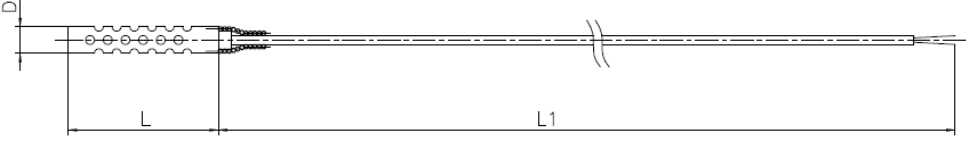

Tube & Wire Type

기본형식 Basic Model	외관형상 Appearance Shape
ISL-2100	 <p>Technical drawing of ISL-2100 thermocouple. It shows a side view with dimensions T (tube thickness), A (tube length), B (tube diameter), and L (total length). The drawing also includes diameter symbols ϕ for the tube and the internal wire.</p>
ISL-2110	 <p>Technical drawing of ISL-2110 thermocouple. It shows a side view with dimensions L (total length) and diameter symbols $\phi 10$, $\phi 5$, and $\phi 12$. The drawing also includes dimensions 2, 6, and 2 for the mounting part.</p>
ISL-2120	 <p>Technical drawing of ISL-2120 thermocouple. It shows a side view with dimensions L (total length), L1 (length of the sensing element), and D (diameter of the sensing element).</p>
ISL-2130	 <p>Technical drawing of ISL-2130 thermocouple. It shows a side view with dimensions L (total length), L1 (length of the sensing element), and D (diameter of the sensing element). The sensing element is shown with a coiled wire.</p>
ISL-2140	 <p>Technical drawing of ISL-2140 thermocouple. It shows a side view with dimensions L (total length), L1 (length of the sensing element), and D (diameter of the sensing element). The sensing element is shown with a coiled wire.</p>

Tube & Wire Type

기본형식 Basic Model	외관형상 Appearance Shape
ISL-2150	
ISL-2160	
ISL-2170	
ISL-2180	
ISL-2190	

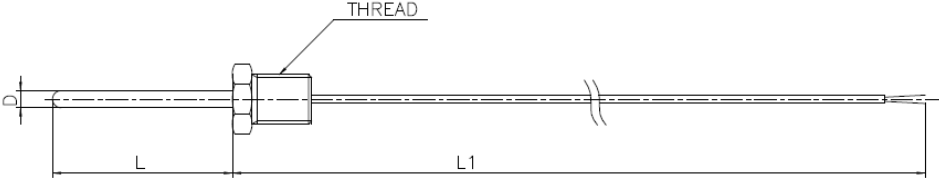
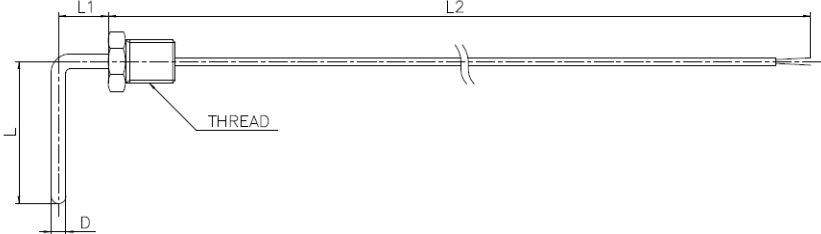
Tube & Wire Type

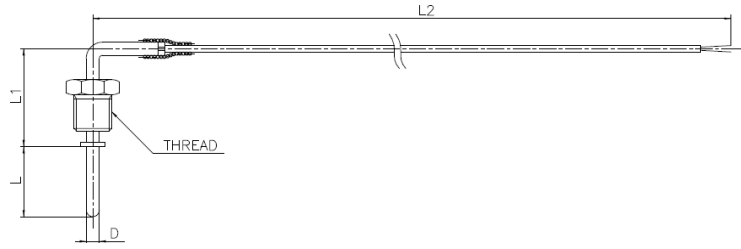
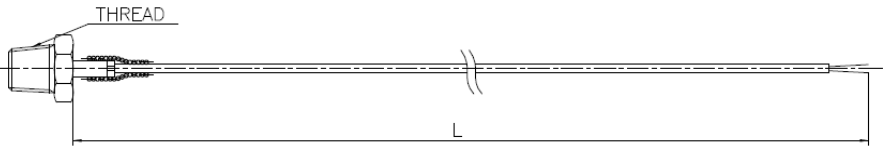
기본형식 Basic Model	외관형상 Appearance Shape
ISL-2200	
ISL-2210	
ISL-2220	
ISL-2230	
ISL-2240	

Tube & Wire Type

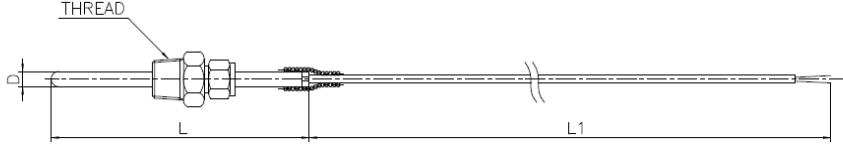
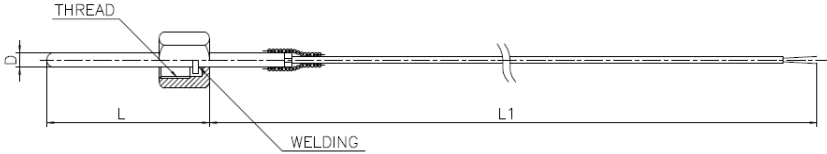
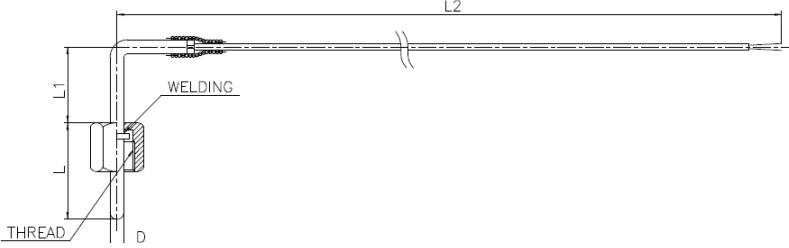
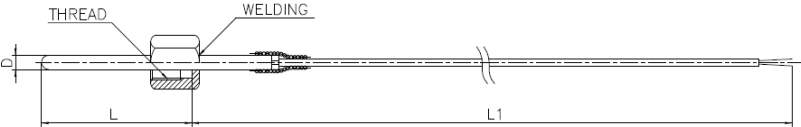
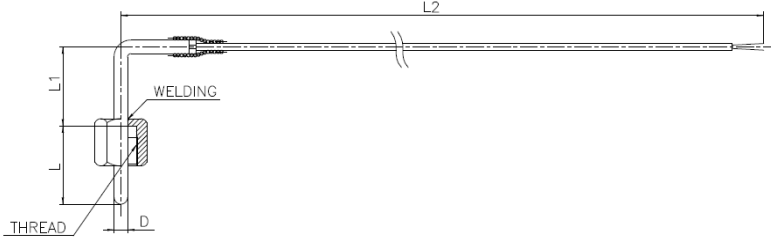
기본형식 Basic Model	외관형상 Appearance Shape
ISL-2250	
ISL-2260	
ISL-2270	
ISL-2280	
ISL-2290	

Tube & Wire Type

기본형식 Basic Model	외관형상 Appearance Shape
ISL-2300	
ISL-2310	
ISL-2320	
ISL-2330	
ISL-2340	

Tube & Wire Type

기본형식 Basic Model	외관형상 Appearance Shape
ISL-2350	

Tube & Terminal Head Type

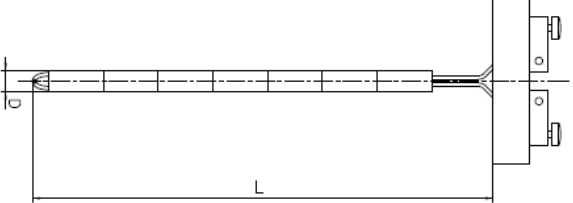
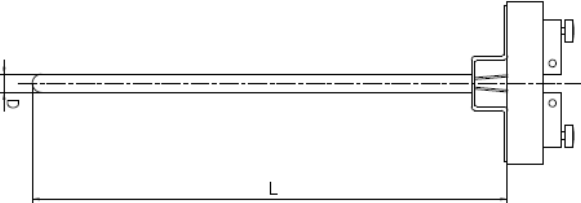
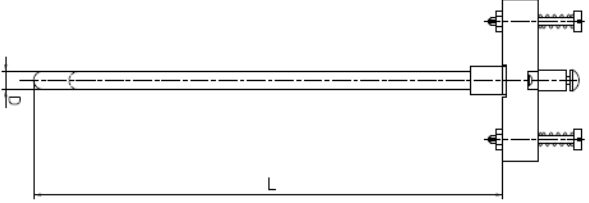
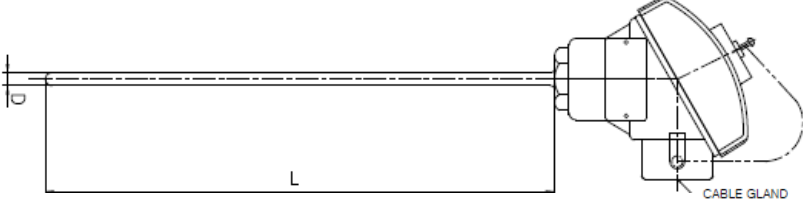
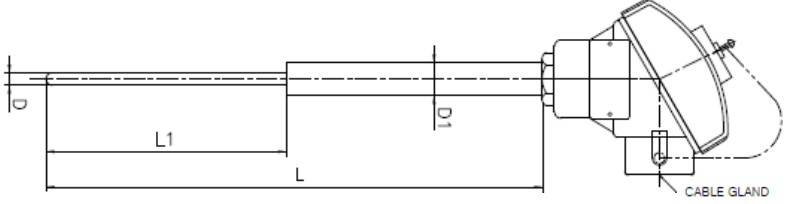
기본형식 Basic Model	외관형상 Appearance Shape
ISL-2500	
ISL-2510	
ISL-2520	
ISL-2530	
ISL-2540	

Tube & Terminal Head Type

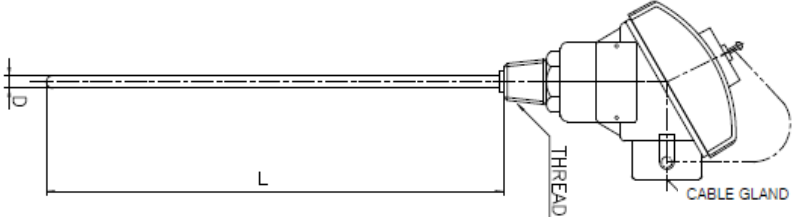
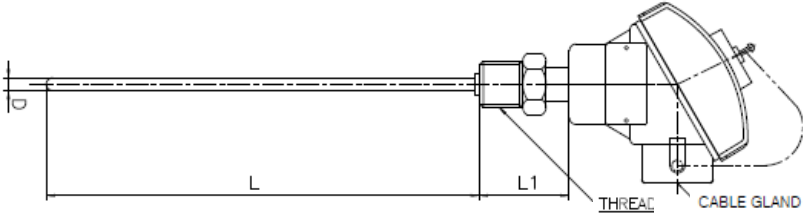
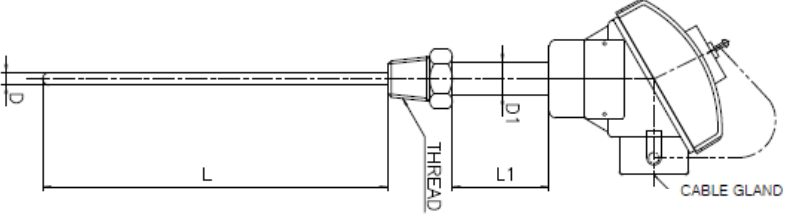
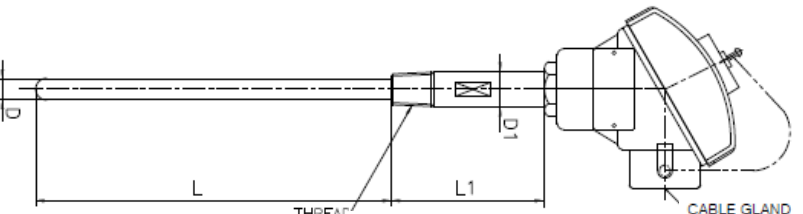
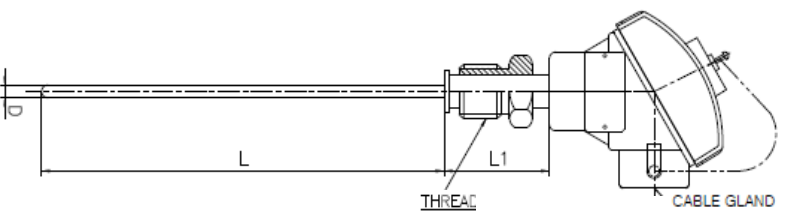
기본형식 Basic Model	외관형상 Appearance Shape
ISL-2550	
ISL-2560	
ISL-2570	
ISL-2580	
ISL-2590	

Tube & Terminal Head Type

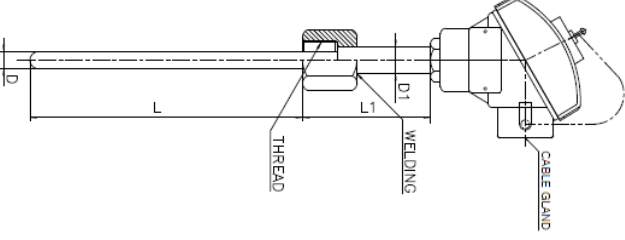
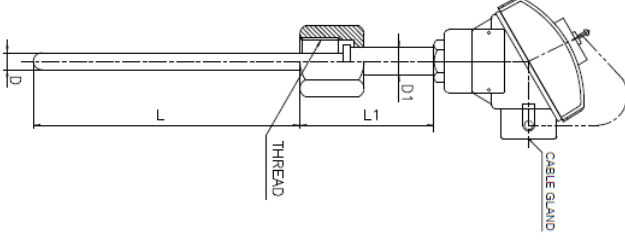
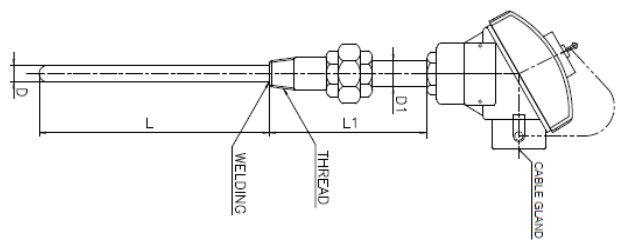
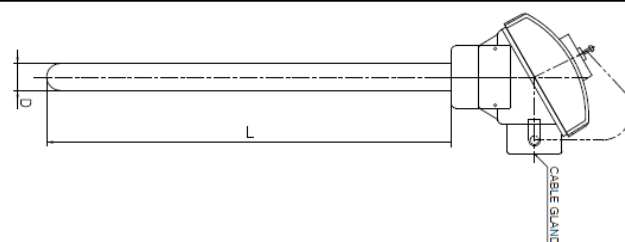
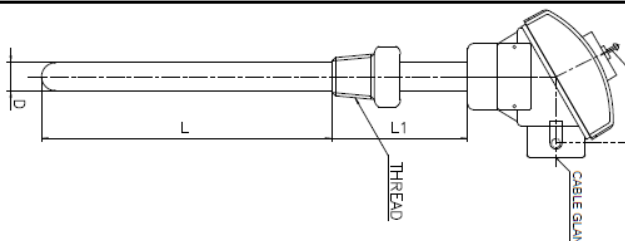
기본형식 Basic Model	외관형상 Appearance Shape
ISL-2591	
ISL-2592	
ISL-2600	
ISL-2610	
ISL-2620	

Tube & Terminal Head Type

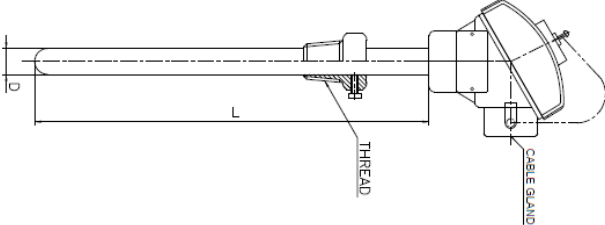
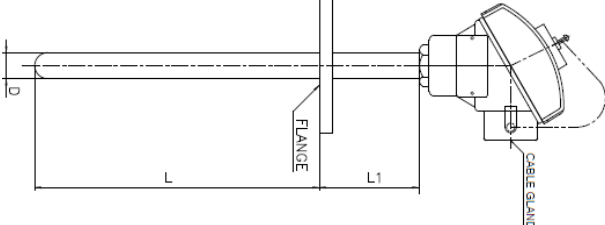
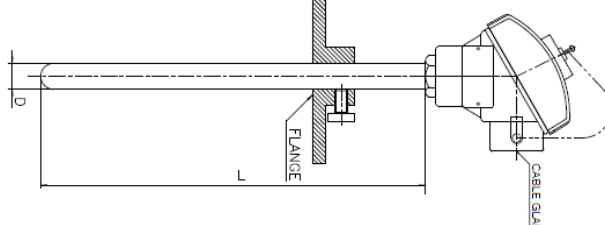
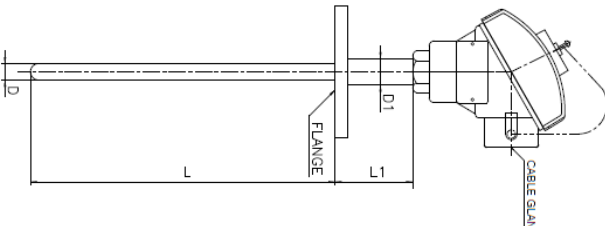
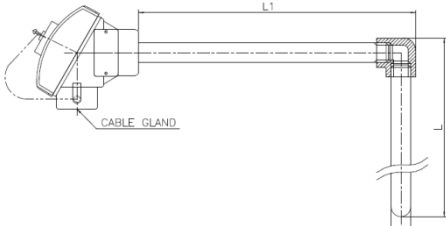
기본형식 Basic Model	외관형상 Appearance Shape
ISL-2630	
ISL-2640	
ISL-2650	
ISL-2660	
ISL-2670	

Tube & Terminal Head Type

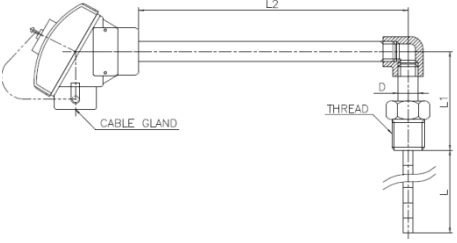
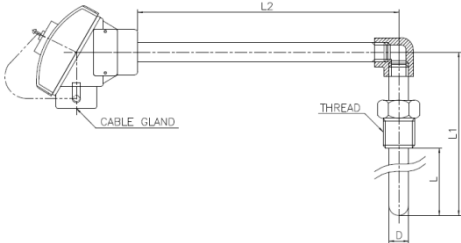
기본형식 Basic Model	외관형상 Appearance Shape
ISL-2680	
ISL-2690	

High Temperature Sensor Type

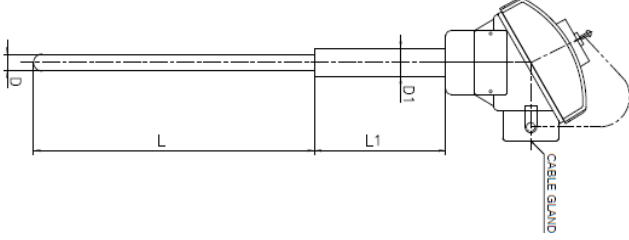
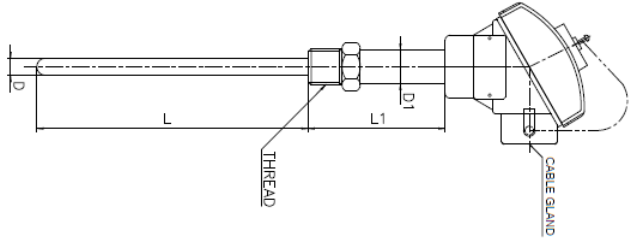
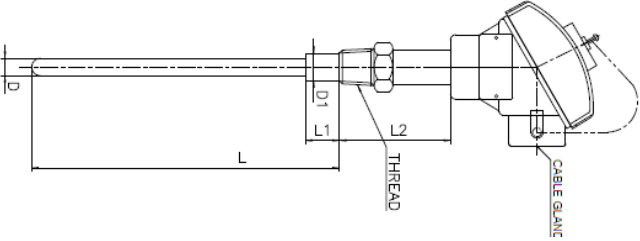
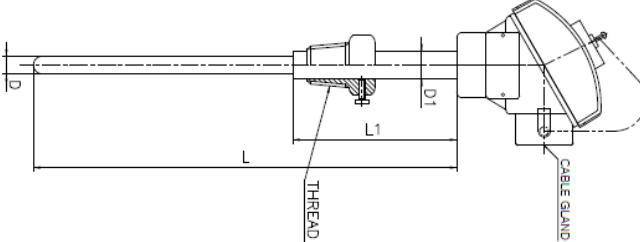
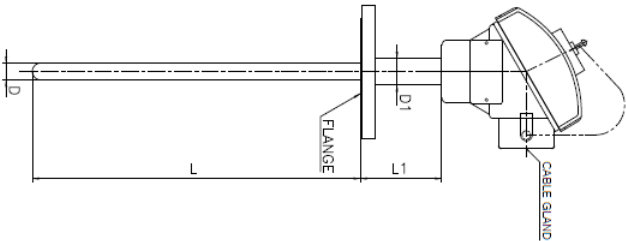
기본형식 Basic Model	외관형상 Appearance Shape
ISL-2800	
ISL-2810	
ISL-2820	
ISL-2830	
ISL-2840	

High Temperature Sensor Type

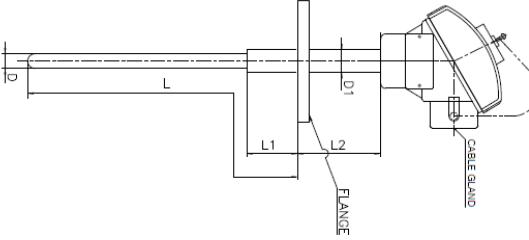
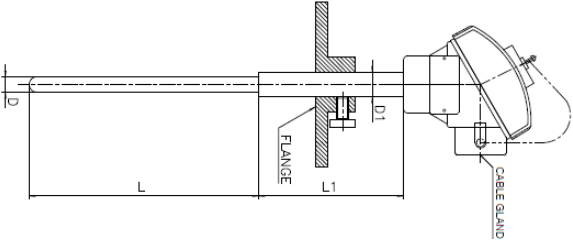
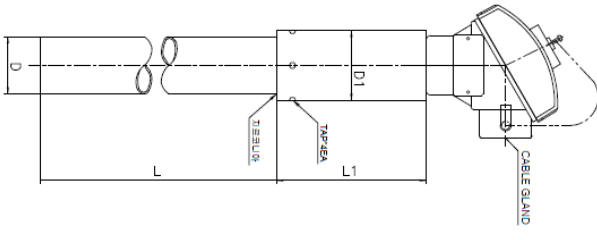
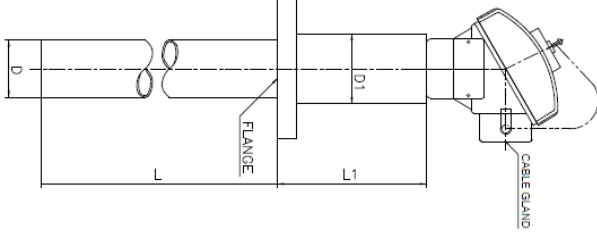
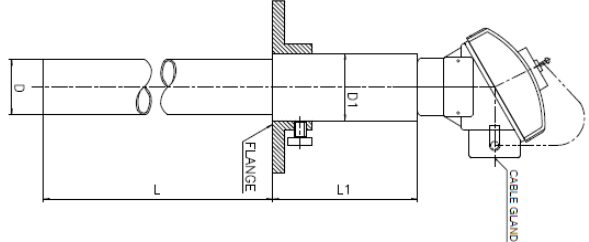
기본형식 Basic Model	외관형상 Appearance Shape
ISL-2850	
ISL-2860	
ISL-2870	
ISL-2880	
ISL-2890	

High Temperature Sensor Type

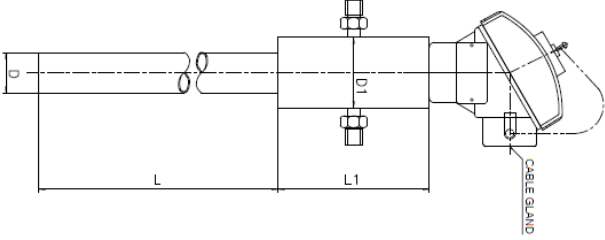
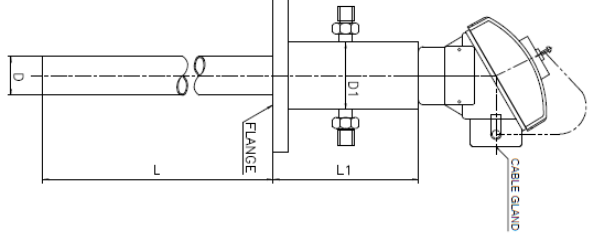
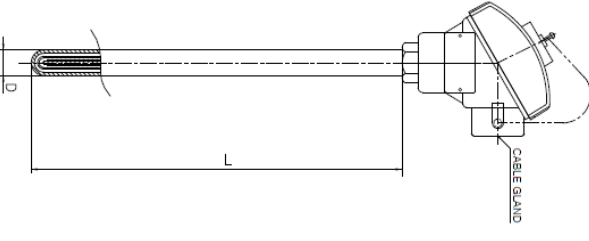
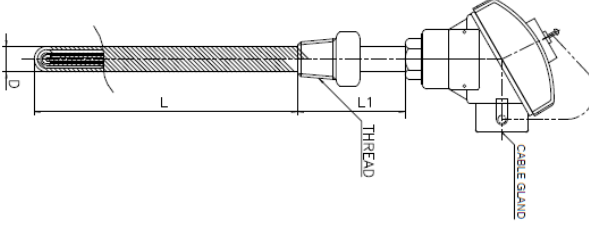
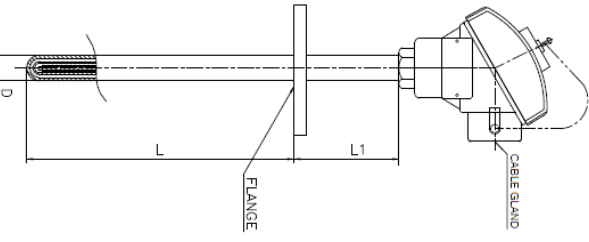
기본형식 Basic Model	외관형상 Appearance Shape
ISL-2900	
ISL-2910	
ISL-2920	
ISL-2930	
ISL-2940	

High Temperature Sensor Type

기본형식 Basic Model	외관형상 Appearance Shape
ISL-2950	